

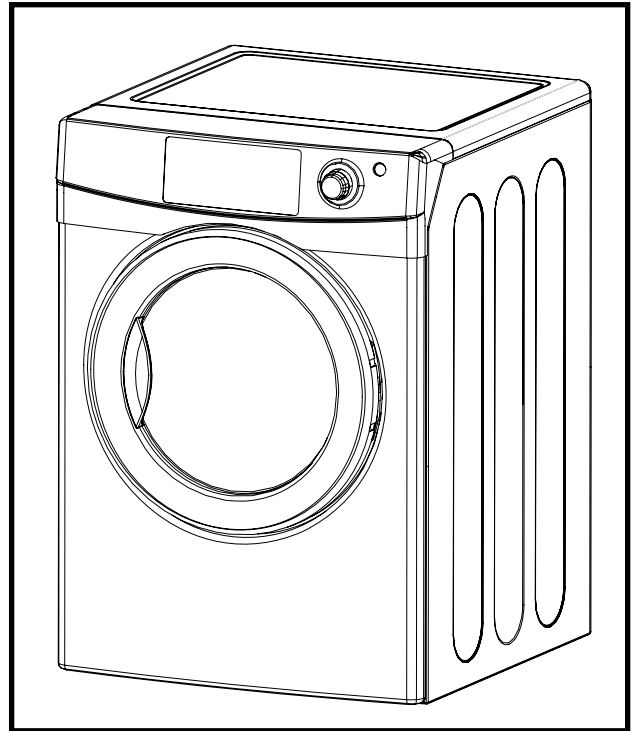

AUTOMATIC DRYER INSTALLATION INSTRUCTIONS

MISE EN SERVICE SÉCHEUSE AUTOMATIQUE

INSTRUCCIONES DE INSTALACIÓN DE LA SECADORA AUTOMÁTICA

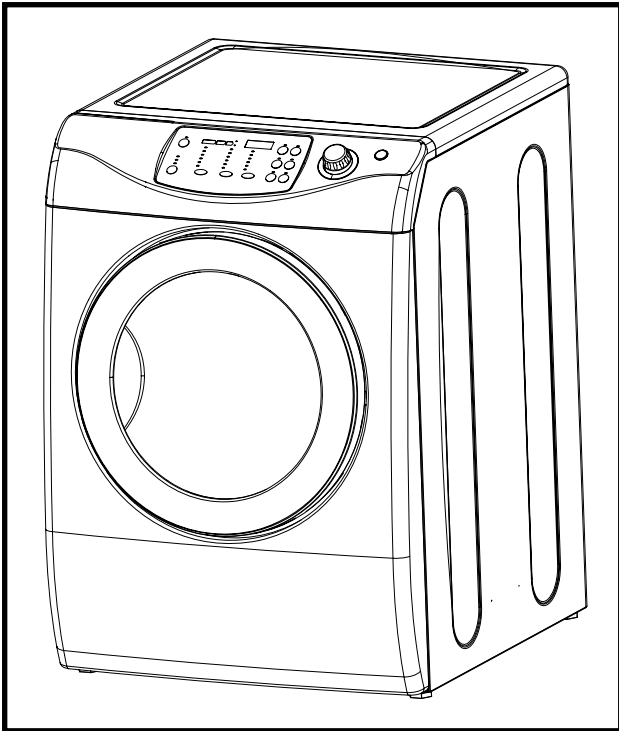

*The installation, including a proper exhaust system,
is the responsibility of the owner.*

*La responsabilité de la mise en service, y compris le système
d'évacuation qui convient, revient au propriétaire.*

*Es responsabilidad del propietario la instalación correcta,
incluso la del sistema de escape.*

**LEAVE THESE INSTRUCTIONS WITH THE OWNER
REMETTRE CES INSTRUCTIONS AU PROPRIÉTAIRE
DEJE ESTAS INSTRUCCIONES CON EL PROPIETARIO**

Tools needed for installation

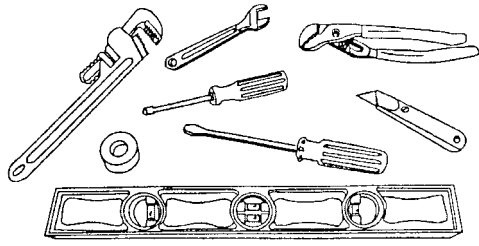

- Teflon tape or pipe joint compound (*gas only*)
- Cutting knife
- Pipe wrench (*gas only*)
- Nut drivers
- Level
- Screw driver (*standard*)
- Duct tape
- Crescent wrench

ITEMS PROVIDED

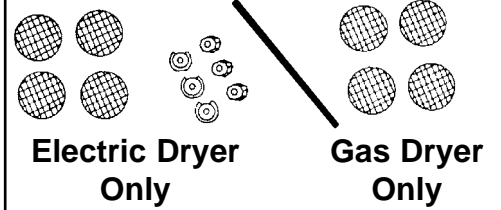

Proper installation is the responsibility of the owner.

HOWEVER, SERVICE CALLS PERFORMED AS A RESULT OF POOR SET-UP, ADJUSTMENT AND CONNECTION ARE THE RESPONSIBILITY OF THE INSTALLER.

Make sure you have everything necessary for proper installation.

1. GROUNDED ELECTRICAL OUTLET is required. See Electric Requirements.
2. POWER CORD for electric dryers (except Canada).
3. GAS LINES (if a gas dryer) must meet National and Local Codes.
4. EXHAUST SYSTEM – must be rigid metal or flexible stiff walled metal exhaust ducting. See Exhaust Requirements.

CABINET DIMENSIONS

9700 series	INCH (CM)
A. Height-overall	38" (96.5)
B. Width	27" (68.6)
C. Depth-With Dryer Door Open 90°	49-3/8" (125.4)
D. Depth	30-3/8" (77.2)
E. Bottom Vent Hole Location - From Back To Center of Hole	7-1/2" (19)
Side Vent Hole - From Back To Center Of Hole	8-1/2" (21.6)

6700 series	INCH (CM)
A. Height-overall	38" (96.5)
B. Width	27" (68.6)
C. Depth-With Dryer Door Open 90°	46-7/16" (123.0)
D. Depth	28" (71.0)
E. Bottom Vent Hole Location - From Back To Center of Hole	7-1/2" (19)
Side Vent Hole - From Back To Center Of Hole	8-1/2" (21.6)

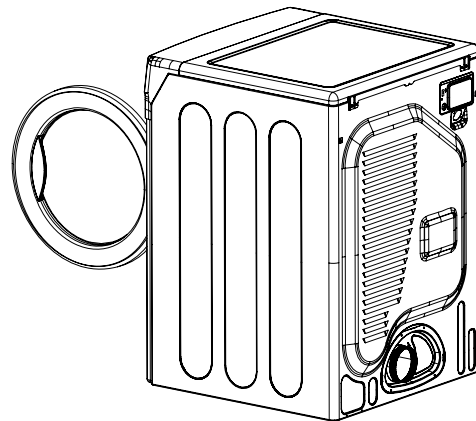
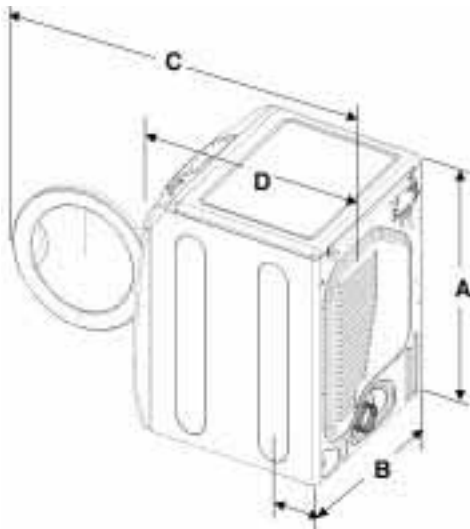

Note:

The height of the dryer from top to floor is 38" with the leveling leg screwed all the way in. The customer can unscrew the leg out an additional 7/8" for a total overall height of 38 7/8".

IMPORTANT TO INSTALLER

Please Read The Following Instructions Carefully Before Starting To Install The Dryer. These Instructions Should Be Retained For Future Reference.

REMOVE THE DOOR FROM ALL DISCARDED APPLIANCES SUCH AS DRYERS TO AVOID THE DANGER OF A CHILD SUFFOCATING.

LOCATION CONSIDERATIONS

The dryer should be located to permit adequate room in front for loading the dryer, and sufficient room behind the dryer for the exhaust system.

This dryer is factory-ready for rear exhaust. To exhaust out the bottom or left side, use the accessory exhaust kit (see Accessories). Instructions are included with the kit.

It is important to make sure the room has adequate make-up air. The area where the dryer is located must not obstruct the flow of combustion or ventilating air.

On gas dryers, adequate clearance as noted on the data plate must be maintained to insure adequate air for combustion and proper operation of the dryer.

THE DRYER **MUST NOT** BE INSTALLED OR STORED IN AN AREA WHERE IT WILL BE EXPOSED TO WATER AND/OR WEATHER. THE DRYER AREA IS TO BE KEPT CLEAR AND FREE FROM COMBUSTIBLE MATERIALS, GASOLINE AND OTHER FLAMMABLE VAPORS AND LIQUIDS. A DRYER PRODUCES COMBUSTIBLE LINT. THE AREA AROUND THE DRYER SHOULD BE KEPT FREE OF LINT.

ALCOVE OR CLOSET INSTALLATION

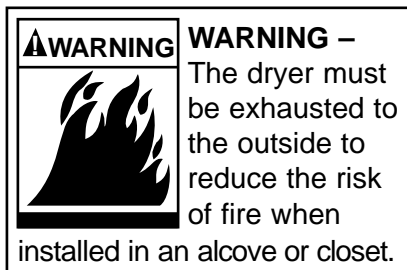

- An appliance installed in a closet shall have no other fuel-burning appliance installed in the same closet.
- **WARNING: To reduce the risk of fire, this dryer MUST BE EXHAUSTED TO THE OUTDOORS.** See **EXHAUST INFORMATION** section.

- Minimum clearances between dryer cabinet and adjacent walls or other surfaces are: 2" front, 0" top, 0" either side and 2-3/8" rear.
- Closet front must have two unobstructed air openings combined total area 72 in² min., located 3 in min. from top and bottom.
Louvered door with equivalent air opening is acceptable.

MOBILE HOME INSTALLATION

The installation of the dryer in mobile homes must conform to the Manufactured Home Construction and Safety Standard Title 24 CFR, Part 32-80 {formerly the Federal standard for Mobile Home Construction and Safety, Title 24, HUD (Part 280), 1975} for the United States,) or CSA Standards Z240 (for Canada). When installing a dryer in a mobile home, provisions for anchoring the dryer to the floor must be made. An anchor bracket kit is available with instructions (see Accessories). Locate in an area that has adequate make up air. A minimum of 72 in² (183 cm²) of unobstructed opening is required. All mobile home installations must be exhausted to the outside with the exhaust duct termination securely fastened to the mobile home structure, using materials that will not support combustion. The exhaust duct may not terminate beneath the mobile home. See the section on exhausting for more information.

EXHAUSTING

Exhausting the dryer to the outside will prevent large amounts of lint and moisture from being blown into the room.

In the United States:

- All dryers must be exhausted to the outside.
- Only rigid or flexible metal duct should be used for exhausting.

In Canada:

- All dryers must be exhausted to the outside.

Outside the U.S. and Canada:

- Refer to local codes.

▲WARNING





WARNING – plastic or nonmetal flexible duct presents a potential fire hazard.

NEVER USE PLASTIC OR NONMETAL FLEXIBLE DUCT.

If your existing ductwork is plastic, nonmetal or combustible, replace it with metal. Use only metal exhaust duct that will not support combustion to insure the containment of exhaust air, heat and lint.

DUCTING REQUIREMENTS

- Use A Minimum Of 4-inch (10.2 Cm) Diameter Rigid Aluminum Or Rigid Galvanized Steel Duct.
- Do not use smaller duct.
- Ducts larger than 4 inches (10.2 cm) in diameter can result in increased lint accumulation. Lint accumulation should be cleaned regularly.
- If flexible metal duct must be used, use the type with a stiff sheet metal wall. Do not use flexible duct with a thin foil wall. Serious blockage can result if flexible metal duct is bent too sharp.
- Never install any type of flexible duct in walls, ceilings or other concealed spaces.
- Keep exhaust duct as straight and short as possible.
- Secure joints with duct tape. Do not use screws.
- DO NOT EXHAUST DRYER INTO ANY WALL, CEILING, CRAWL SPACE OR A CONCEALED SPACE OF A BUILDING, GAS VENT, ANY OTHER COMMON DUCT OR CHIMNEY. THIS COULD CREATE A FIRE HAZARD FROM LINT EXPELLED BY THE DRYER.
- Plastic flexible duct can kink, sag, be punctured, reduce airflow, extend drying times and affect dryer operation.

ELECTRIC AND GAS DRYER				
Weather Hood Type				
Recommended			Use only for short run installation	
				
	4" (10,16 cm)		2 1/2" (6,35 cm)	
No. of 90° elbows	Rigid	Metallic Flexible*	Rigid	Metallic Flexible*
0	24.4 m (80 ft.)	12.4 m (41 ft.)	22.6 m (74 ft.)	10.1 m (33 ft.)
1	20.7 m (68 ft.)	11.2 m (37 ft.)	18.9 m (62 ft.)	8.8 m (29 ft.)
2	17.4 m (57 ft.)	10.1 m (33 ft.)	15.5 m (51 ft.)	7.6 m (25 ft.)
3	14.3m (47 ft.)	9.0 m (29 ft.)	12.5 m (41 ft.)	6.5 m (21 ft.)

* Do not use non metallic flexible duct.

- Exhaust systems longer than recommended can extend drying times, affect machine operation and may collect lint.
- The exhaust duct should end with an exhaust hood with a swing out damper to prevent back drafts and entry of wildlife. Never use an exhaust hood with a magnetic damper.
- The hood should have at least 12 inches (30.5 cm) of clearance between the bottom of the hood and the ground or other obstruction. The hood opening should point down. Never install a screen over the exhaust outlet.
- When possible, do not exhaust the dryer directly into a window well in order to avoid lint build-up. Do not exhaust under a house or porch.
- If exhaust ductwork must run through an unheated area, the duct should be insulated and slope slightly down towards the exhaust hood to reduce condensation and lint build-up.
- Inspect and clean the interior or the exhaust system at least once a year. Disconnect electrical service prior to cleaning.
- Frequently check to be sure the exhaust hood damper opens and closes freely.

If new dryer is installed into an existing exhaust system you must be sure:

- The exhaust system meets all local, state and national codes.
- That plastic flexible duct is not used.
- Inspect and clean all lint accumulation from the interior of the existing duct.
- The duct is not kinked or crushed.
- The exhaust hood damper opens and closes freely.

The static pressure in any exhaust system must not exceed 0.83 inches of water column, or be less than 0.

This can be measured with the dryer running with a manometer at the point where the exhaust duct connects to the dryer. A no heat setting should be used.

The dryer tumbler should be empty and the lint filter clean.

GAS REQUIREMENTS

Use only Natural or LP (liquid propane) gases.

THE INSTALLATION MUST CONFORM WITH LOCAL CODES, OR IN THE ABSENCE OF LOCAL CODES, WITH THE NATIONAL FUEL GAS CODE ANSI/Z223.1, LATEST REVISION (FOR THE UNITED STATES), OR WITH THE CAN/CGA-B149 INSTALLATION CODES (FOR CANADA).

Gas dryers are equipped with a burner orifice for operation on NATURAL gas. **If the dryer is to be operated on LP (liquid propane) gas, it must be converted for safe and proper performance and must be converted by a qualified service technician.** Conversion kits from NATURAL to LP, or LP to NATURAL are available through your local Maytag dealer (see Accessories). If other conversions are required, check with the local gas utility for specific information concerning conversion requirements.

A 1/2" (1.27 cm) gas supply line is recommended and must be reduced to connect to the 3/8" (1.0 cm) gas line on the dryer.

The National Fuel Gas Code requires that an accessible, approved manual gas shut off valve be installed within 6 feet of the dryer.

Gas Dryers installed in residential garages must be elevated 18 inches (46 cm) above the floor.

Additionally, a 1/8" (.3 cm) N.P.T. (National Pipe Thread) plugged tapping, accessible for test gauge connection, must be installed immediately upstream of the gas supply connection to the dryer.

The dryer must be disconnected from the gas supply piping system during any pressure testing of the system.

DO NOT re-use old flexible metal gas line. Flexible gas line must be design certified by American Gas Association (CGA in Canada). **NOTE:** Any pipe joint compound used must be resistant to the action of any liquefied petroleum gas.

NOTE: As a courtesy, most local gas utilities will inspect a gas appliance installation.

GAS IGNITION –

This dryer uses an automatic ignition system to ignite the burner. **There is no constant burning pilot.**

COMMONWEALTH OF MASSACHUSETTS INSTALLATION INSTRUCTIONS
This gas dryer must be installed by a licensed plumber or gas fitter
A "T" handle manual gas valve must be installed in the gas supply line to this gas dryer.
If a flexible gas connector is used to install this gas dryer, the connector must have a maximum length of 3 feet. (36 inches)

 WARNING
Gas leaks may occur in your system and result in a dangerous situation. Gas leaks may not be detected by smell alone. Gas suppliers recommend you purchase and install a UL approved gas detector. Install and use in accordance with the manufacturer's instructions.

ELECTRICAL REQUIREMENTS

NOTE: Wiring diagram is located below the Top Cover.

Export models (not U.S. or Canada): See Additional Instructions for Export Models on the other side of this sheet.



- Improper connection of the equipment grounding conductor can result in a risk of electric shock. Check with a qualified electrician or serviceman if you are in doubt as to whether the appliance is properly grounded. Do not modify the plug provided with the appliance – if it will not fit the outlet, have a proper outlet installed by a qualified electrician.
- To prevent unnecessary risk of fire, electrical shock or personal injury, all wiring and grounding must be done in accordance with local codes, or in the absence of local codes, with the National Electrical Code, ANSI/NFPA No. 70-Latest Revision (for the US) or the Canadian Electrical Code CSA C22.1 - Latest Revisions and local codes and ordinances. It is the personal responsibility and obligation of the appliance owner to provide adequate electrical services for this appliance
- All gas installations must be done in accordance with the national Fuel Code ANSI/Z2231 - Last revision (for United States) or CAN/CGA - B149 Installation Codes - Latest Revision (for Canada) and local codes and ordinances.

GROUNDING

This dryer must be grounded. In the event of malfunction or breakdown, the ground will reduce the risk of electrical shock by providing a path of least resistance for electrical current.

GAS MODELS

This appliance is equipped with a cord having an equipment-grounding conductor and a grounding plug. The plug must be plugged into an appropriate outlet that is properly installed and grounded in accordance with all local codes and ordinances.

Do not modify the plug provided with the appliance – if it will not fit the outlet, have a proper outlet installed by a qualified electrician.

If a separate ground is required by local codes, a grounding kit (Part No. 12001875) is available. It contains ground wire, clamp, ground screw and washer. Connect ground wire to back of unit with the cabinet ground screw and washer. Secure other end of ground wire to a suitable external ground connection. The wire may be secured with the clamp to a grounded COLD metal water pipe.

NEVER CONNECT GROUND WIRE TO PLASTIC PLUMBING LINES, GAS LINES OR HOT WATER PIPES.

ELECTRIC MODELS

This appliance is equipped with a cord having an equipment-grounding conductor and a grounding plug. The plug must be plugged into an appropriate outlet that is properly installed and grounded in accordance with all local codes and ordinances.

If a power cord is not used and the electric dryer is to be permanently wired, the dryer must be connected to a grounded metal, permanent wiring system; or an equipment grounding conductor must be run with the circuit conductors and connected to the equipment grounding terminal.

ELECTRICAL CONNECTIONS

BEFORE OPERATING OR TESTING, follow all grounding instructions in Grounding Section.

An individual branch (or separate) circuit serving only this appliance is recommended. **DO NOT USE AN EXTENSION CORD.**

GAS MODELS – U.S. and Canada

A 120 volt, 60 Hz AC, approved electrical service, with a 15 ampere fuse or circuit breaker is required.

ELECTRIC MODELS – U.S. Only

Most U.S. dryers, as manufactured, require a 120/240 volt, 60 Hz AC approved electrical service. Some require 120/208 volt, 60 Hz approved electrical service. The electric service requirements can be found on the data label located on the front behind the door. A 30 ampere fuse or circuit breaker on both sides of the line is required.

- If a power cord is used, the cord should be plugged into a 30-ampere receptacle.
- The power cord is **NOT** provided with U.S. electric model dryers.

IMPORTANT: When permitted by local codes, the dryer electrical supply may be connected by means of a new power supply cord kit, marked for use with clothes dryer, that is U.L. listed, rated at 120/240 volts minimum, 30 amperes with three No. 10 copper wire conductors terminated with closed loop terminals, open-end spade lugs with turned up ends or with tinned leads.

1. size of the conductors and the type of cord.
2. 3/4 in. (1.9 cm) UL-listed strain relief

- Do not reuse a power supply cord from an old dryer. The power cord electric supply wiring must be retained at the dryer cabinet with a suitable UL listed strain relief.
- Where grounding through the neutral conductor is prohibited. Grounding through the neutral conductor is prohibited for (1) new branch-circuit installations, (2) mobile homes, and (3) recreational vehicles, and (4) areas where local codes prohibit grounding through the neutral conductor.
(Use 4-prong plug for 4 wire receptacle, NEMA type 14-30R)

ELECTRIC MODELS - Canada Only

- A 120/240 volt, 60 Hz AC approved electrical service fused through a 30 ampere fuse or circuit breaker on both sides of the line is required.
- All Canadian models are shipped with the power cord attached. The power cord should be plugged into a 30 ampere receptacle.

NOTE: It is not permissible to convert a dryer in Canada to 208 volts.

REPLACEMENT PARTS AND ACCESSORIES

If your dryer requires replacement parts or accessories, contact the dealer from whom you purchased your dryer or Maytag Customer Service, Box 2370, Cleveland, Tennessee 37320-2370, phone 423-472-3333, for information on the nearest authorized Maytag Parts Distributor.

INSTALLATION

Parts and literature are packaged inside of dryer drum.

To Install...

- 1.** Move dryer to an appropriate location for installation. Consider installing the dryer before the washer in side-by-side installations, to allow access to gas, electrical and exhaust connections. Lay two of the carton corner posts on the floor. Tip the dryer on its side so it will lay across both corner posts.
- 2.** Set the dryer back in an upright position.
- 3.** Review the Exhausting Section before installing the exhaust system. Install the ductwork from the dryer to the exhaust hood. The crimped end of the duct sections must point away from the dryer. **DO NOT** use sheet metal screws when assembling ducting. These joints should be taped. **Never use plastic flexible exhaust material.**

Tip for tight installations: install a section of exhaust system to the dryer before moving the dryer in place. Use duct tape to secure this section to the dryer but do not cover louvers in dryer cabinet.

4. Review Electrical Requirements Section.

BEFORE OPERATING OR TESTING, follow the grounding instructions in the Grounding Section.

U.S. MODELS:

IMPORTANT - All U.S. models are produced for a **3-WIRE SYSTEM CONNECTION**. The dryer frame is grounded to the neutral conductor at the terminal block.

A **4-WIRE SYSTEM CONNECTION** is required for new or remodeled construction, mobile homes, or if local codes do not permit grounding through neutral. If the 4-wire system is used, the dryer frame cannot be grounded to the neutral conductor at the terminal block. Refer to the following instructions for 3- and 4-WIRE SYSTEM CONNECTIONS.

Remove the terminal block cover plate.

Insert the power cord with a U.L. listed strain relief through the hole provided in the cabinet near the terminal block.

NOTE: a strain relief must be used.

Do not loosen the nuts already installed on the terminal block. Be sure they are tight. Use a 3/8" (1 cm) deep well socket.

5. Review Gas Requirements Section.

Remove the pipe thread protective cap.

Apply pipe joint compound or about 1 1/2 wraps of Teflon tape over all threaded connections.

NOTE: Pipe joint compound must be resistant to the action of any liquefied petroleum gas.

Connect the gas supply to the dryer. An additional fitting is required to connect the 3/4" (1.9 cm) female thread end of a flexible connector to the 3/8" (1 cm) male threaded end on the dryer. Securely tighten the gas line fitting over threads.

Turn on the gas supply. Check all gas connections for leaks using a soap solution. If bubbles occur, tighten the connections and recheck. **DO NOT use an open flame to check for gas leaks.**

3-WIRE SYSTEM CONNECTIONS

1. Loosen or remove center terminal block screw.
2. Connect neutral wire (white or center wire) of power supply cord to the center, silver colored terminal screw of the terminal block. Tighten screw.
3. Connect the other wires to outer terminal block screws. Tighten screws.
4. Tighten strain relief screws.
5. Insert tab of terminal block cover into slot of dryer rear panel. Secure cover with hold-down screw.

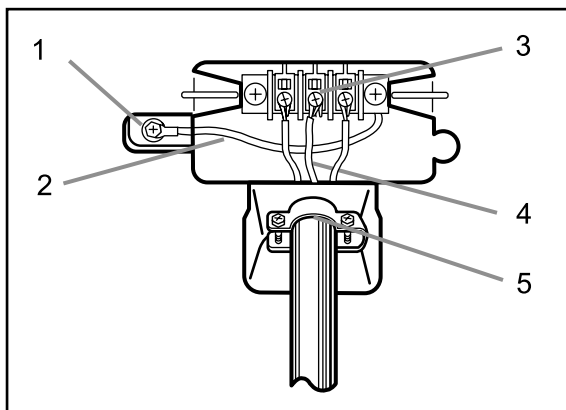

1. External ground connector
2. Neutral grounding wire (green/yellow)
3. Center silver-colored terminal block screw
4. Neutral wire (white or center wire)
5. 3/4 in. (1.9 cm) UL-listed strain relief

WARNING: If converting from a 4-wire electrical system to a 3-wire, the ground strap must be reconnected to the terminal block support to ground the dryer frame to the neutral conductor.

4-WIRE SYSTEM CONNECTIONS

1. Remove center terminal block screw.
2. Connect ground wire (green or bare) of power supply cord to external ground conductor screw.
3. Connect neutral wire (white or center wire) of power supply cord and appliance ground wire (green with yellow stripes) under central screw of the terminal block.
4. Connect the other wires to outer terminal block screws. Tighten screws.
5. Tighten strain relief screws.
6. Insert tab of terminal block cover into slot of dryer rear panel. Secure cover with hold-down screw.

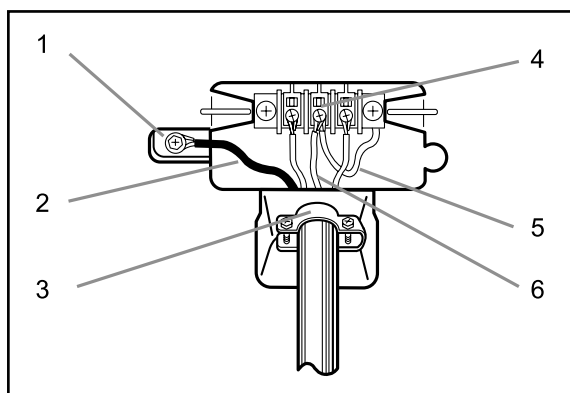

1. External ground connector
2. Green or bare copper wire of power supply cord
3. 3/4 in. (1.9 cm) UL-listed strain relief
4. Center silver-colored terminal block screw
5. Grounding wire (green/yellow)
6. Neutral wire (white or center wire)

EXPORT MODELS

Refer to last page of installation instructions.

6. With a level, check the dryer, and make necessary adjustments to the leveling legs.
7. At this time, make sure all gas connections (on gas models), exhaust and electrical connections are complete. Plug dryer in, and check operation by using the check list below.
8. (GAS MODELS ONLY)

The burner may not ignite initially due to air in the gas line. Allowing the dryer to operate on a heat setting will purge the line. If the gas does not ignite within five minutes, turn the dryer off and wait

5 minutes. Be sure the gas supply to the dryer has been turned on. In order to confirm gas ignition, check the exhaust for heat.

FINAL INSTALLATION CHECK LIST

- Dryer is plugged into electrical outlet and is properly grounded.
- Exhaust duct work is hooked up and joints taped.
- Plastic flexible duct is NOT used.
- Use rigid or stiff walled flexible metal vent material.
- Dryer is level with all legs firmly on the floor.
- Gas Models – gas is turned on, there are no gas leaks.
- Start dryer to confirm dryer runs, heats, shuts off.
- Demonstrate use to consumer.

HOUSEHOLD INSTALLATION ACCESSORIES

- Vent hood – 4" (10.16 cm) opening – 059129
- Aluminum pipe – 4" x 24" (10.16 cm x 60.96 cm) – 059130
- Aluminum elbow – 4" (10.16 cm) – 059131
- Aluminum window plate – 15" x 20" (38.10 cm x 50.80 cm) – 4" (10.16 cm) hole – 059134
- Flexible aluminum vent duct – 4" (10.16 cm) diameter – 38" (81.28 cm) length stretches to 8' (2.44 cm) – 304353
- Clamp for flexible aluminum duct – 304630
- Exhaust duct kit for base or left side exhausting – 12002641
- Rectangular vent kit – 059144
- Dacron lint bag – 311353
- NATURAL to LP conversion kit – 306195
- LP to NATURAL conversion kit – 306204
- Anchor bracket kit – 12002643
- Grounding kit – 12001875
- Power cords – 240 v, 30 A
 - 4' (121.9 cm) – 3-wire – 33001780
 - 5' (152.4 cm) – 3-wire – 33001822
 - 6' (182.9 cm) – 3-wire – 33001823
 - 10' (304.8 cm) – 3-wire – 33001838
 - 4' (121.9 cm) – 4-wire – 33001781
 - 5' (152.4 cm) – 4-wire – 33001824
 - 6' (182.9 cm) – 4-wire – 33001825
 - 10' (304.8 cm) – 4-wire – 33001838

ADDITIONAL INSTRUCTIONS FOR EXPORT MODELS

(Not U.S. Mexico, or Canada) Contact the distributor that sold the appliance or: Maytag International, 1475 East Woodfield Road Schaumburg, Illinois 60173 Phone: 847-273-3100, for information on product, shipping damage, replacement parts and accessories.

Maytag dryer models manufactured for operation on 60Hz AC are not designed for use on 50Hz AC electrical service and conversion of the product from 60 to 50Hz operation is not recommended. For additional information on 50Hz product, contact Maytag International. The electric service requirements can be found on the data label located on the front of the dryer behind the door.

EXPORT ELECTRIC MODELS

Some export electric models are manufactured for operation on 230/240 volt, 50 Hz and some for operation on 220 Volt, 60 Hz electric service. A two-wire approved electrical service with a 30-amp fuse or circuit breaker is required. The dryer must be earthed with an earthing wire.

IMPORTANT: When permitted by local codes the dryer electrical supply may be connected by means of a power supply cord kit. The cord must be marked for use with clothes dryers, agency listed, rated for 240 volts - 30 amp minimum. The cord should be terminated with closed loop terminals, open-end spade lugs with turned up ends or with tinned leads. Do not reuse a power supply cord from an old dryer. The power cord or electric supply wiring must be retained at the dryer cabinet with a suitable agency listed strain relief.

2-WIRE SYSTEM CONNECTIONS

1. Loosen or remove center terminal block screw.
2. Connect neutral wire (White or center wire) of power supply cord to the center, silver colored terminal screw of the terminal block. Tighten screw.
3. Connect the other wire to outer terminal block screw. Tighten screw.
4. Tighten strain relief screws.
5. Insert tab of terminal block cover into slot of dryer rear panel, Secure cover with hold-down screw.

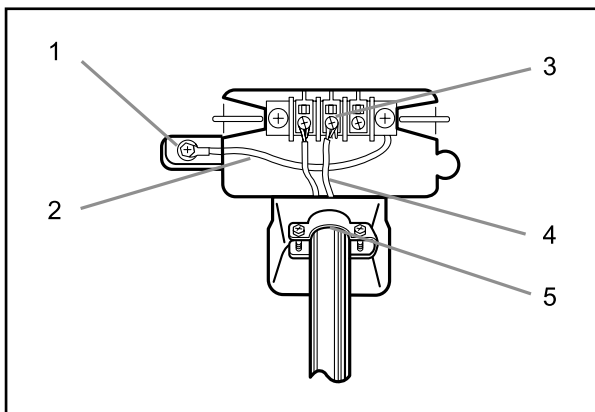

1. External ground connector
2. Neutral grounding wire (green.yellow)
3. Center silver-colored terminal clock screw.
4. Neutral wire (white or center wire)
5. 3/4 in. (1.9 c m) UL-listed strain relief
6. Neutral wire (white or center wire)

BEFORE OPERATING OR TESTING, be sure the machine is properly grounded.

EXPORT GAS MODELS

Some export gas models are manufactured for operation on 230/240 volt, 50 Hz and some for operation on 220 volt, 60 Hz electrical service with a 15 amp fuse or circuit breaker.

Export gas models have been manufactured for use with natural gas having a higher heating value of approximately 1025 BTU per cubic foot. Conversion to LP gas with a higher heating value must be performed by a qualified service technician. A 33002927 Natural Gas to LP Gas, 50 Hz conversion kit is available.

Door Reversal

1. Disconnect power supply to unit.

2. Remove 2 screws on door hinge.

3. Lift the door and remove from dryer.

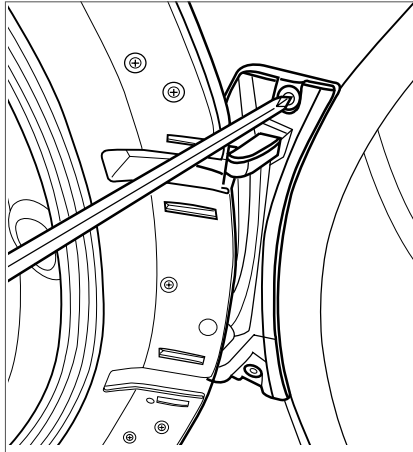

4. Remove 2 screws on opposite side of door hinge.

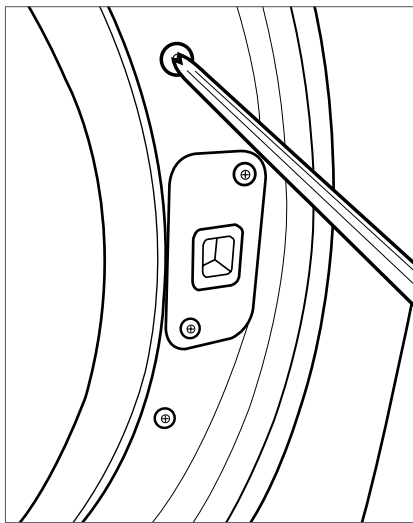

5. Remove 2 screws on holder lever.

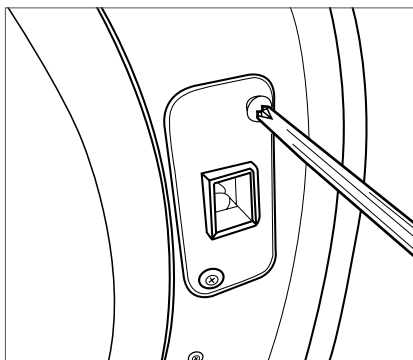

6. Locate door at the other side and reassemble door to dryer.

7. Reassemble holder lever.

8. Reassemble 2 screws in remained holes.

